

HYPERBOLIC | MIXER



ENGINEERED FIRSTS | BUILT TO LAST

OVERVIEW

High energy efficiency is critical in today's world. Energy costs are rising and there's a need to reduce our carbon footprint.

The DBS Hyperbolic Mixer provides the required mixing with a minimal energy expenditure.

FEATURES

The DBS Hyperbolic Mixer is specifically designed for process mixing, such as flocculation, suspension, homogenization, and sub-surface aeration. The rotor operates at the bottom of a mixing basin, efficiently drawing water down and discharging it in a horizontal direction. This induced flow circulates the water in the tank from bottom to top to maintain all solids in suspension.

High-efficiency design of the speed reducer minimizes parasitic power losses and maximizes the power transferred to the water. High service factors are used to select the speed reducer – with calculated life exceeding 100,000 hours.

The heavy-duty output bearings provide adequate support against all loads imposed by the rotor, eliminating the need for a lower guide bearing. Oversized drive shaft and robust mounting base minimize rotor deflection and vibrations.

Wetted parts are manufactured from 300 Series stainless steel and 5052 Marine Grade Aluminum for corrosion resistance. Special coatings and materials can be provided at customer's request for very saline or aggressive wastewaters.

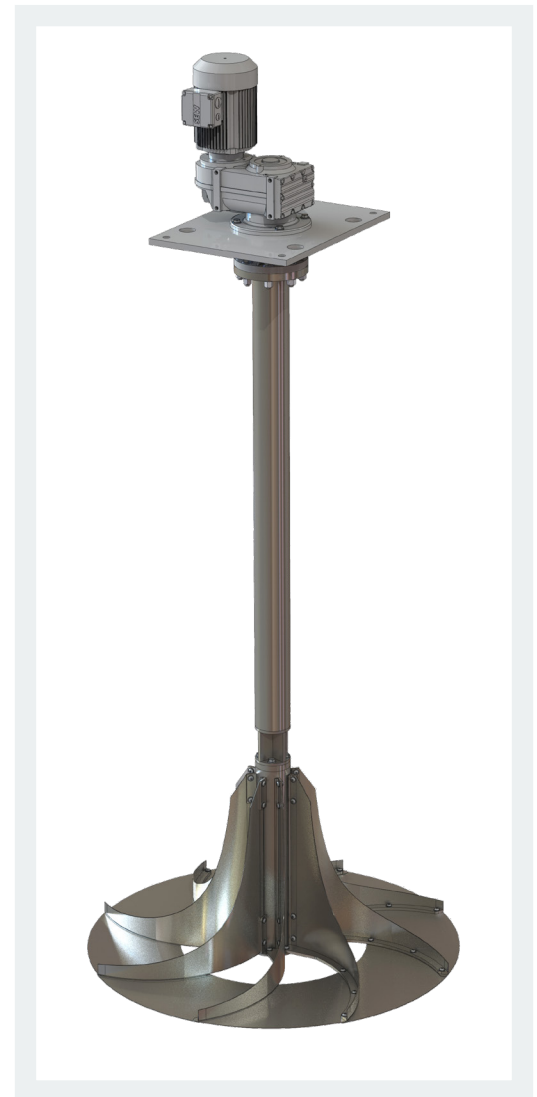

HYPERBOLIC MIXER

Backwards-curved pump blades are specifically shaped and oriented to move the maximum volume of water with minimal power input. Mixers are available from 1 HP (0.75 kW) to 30 HP (22 kW), as well as custom hyperbolic mixers for industrial applications.



TOP VIEW

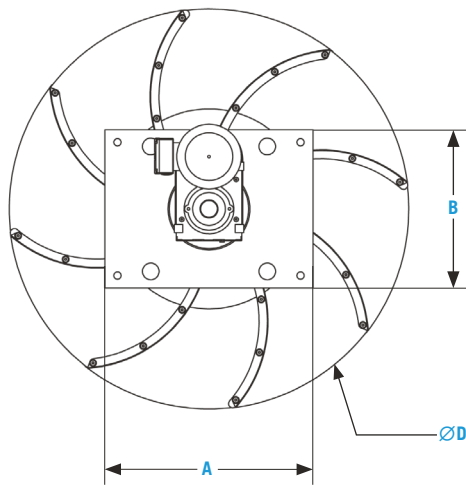

SIDE VIEW

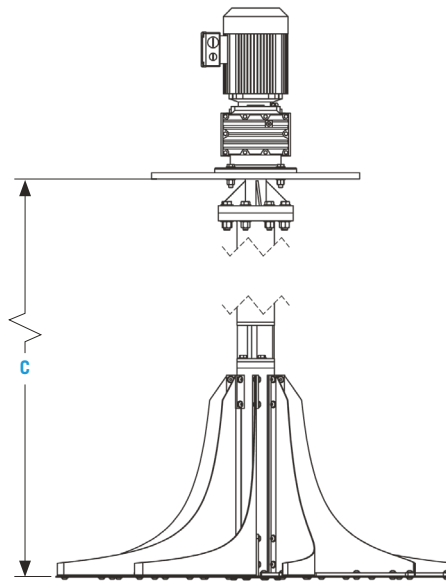

PERFORMANCE TESTING

- Detailed CFD analysis is used to fine-tune rotor performance.
- Analysis of customer's tank is available upon request.

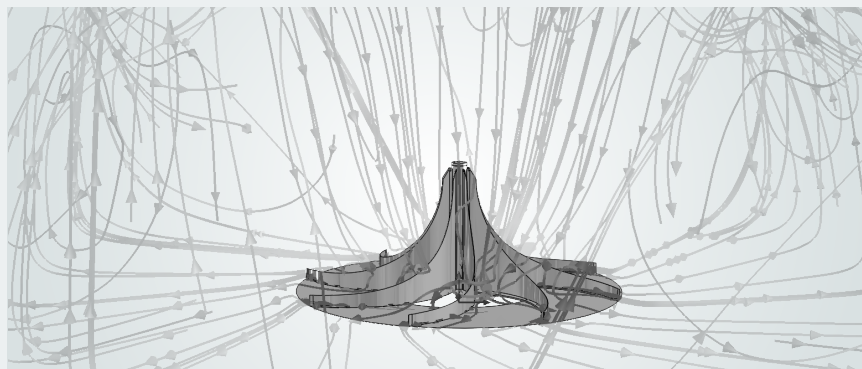

MODEL	POWER		RPM	A		B		C _{max}		ØD	
	HP	KW		IN	MM	IN	MM	IN	MM	IN	MM
HM-1400	1-5	0.75-3.7	40-70	18	457	24	61	120	3048	55	1400
HM-1900	2-10	1.5 -7.5	32-54	24	610	36	91	180	4572	75	1900
HM-2500	2-30	1.5-22.4	18-42	24	610	36	91	300	7620	102	2500

¹ Metric flanges are available.

Replace the * with the primary reducer option selected.



HYPERBOLIC MIXER | ROTOR
MODEL HM-2500-23-5

- CLARIFIER & THICKENER DRIVES
- RETROFITS
- LOW-SPEED SURFACE AERATORS
- ROTARY DISTRIBUTOR CENTER MECHANISMS

DBS MANUFACTURING

404.768.2131

engineering@dbsmfg.com
dbsmfg.com
45 SouthWoods Parkway
Atlanta, Georgia. 30354